

鋼製密閉沖底型電纜線槽

**Steel Ventilated Through
Type Cable Tray**

欣歐企業股份有限公司

SENCO ENTERPRISE CO., LTD.

831 高雄市大寮區光華路 470 巷 138 號

電話: (07)788-6336

傳真: (07)788-6339



No.138, Lane 470, Guanghua Rd., Daliao District,
Kaohsiung City 831, Taiwan.

website: www.senco.com.tw

e-mail: senco@ms18.hinet.net

電纜線槽製造標準

一. 製造標準

1. CNS 13303 C4466 金屬電纜線架系統
2. NEMA VE1-1996 METALLIC CABLE TRAY SYSTEMS

二. 材料標準

1. CNS 1244 熱浸法鍍鋅鋼片
2. CNS 10804 烤漆熱浸鍍鋅鋼片及鋼捲
3. CNS 2068 鋁及鋁合金之合金種類及鍊度符號
4. CNS 2253 鋁及鋁合金之片及板
5. CNS 2257 鋁擠型條
6. CNS 8499 冷軋不銹鋼鋼片及鋼板

三. 表面處理標準

1. CNS 8590 鋁及鋁合金之硫酸陽極氧化處理作業
2. CNS 8507 鋁及鋁合金之陽極氧化皮膜
3. CNS 10007 鋼鐵之熱浸法鍍鋅
4. CNS 770 烤漆
5. CNS 4938 環氧樹脂漆

四. 檢驗標準

1. CNS 13303 C4466 金屬電纜線架系統
2. NEMA VE1-1996 METALLIC CABLE TRAY SYSTEMS
3. CNS 2608 鋼料之檢驗通則
4. CNS 1361 熱浸法鍍鋅鋼片檢驗法
5. CNS 8500 冷軋不銹鋼鋼片及鋼板檢驗法
6. CNS 2258 鋁擠型條檢驗法
7. CNS 2254 鋁及鋁合金之片及板檢驗法
8. CNS 8406 鋁及鋁合金之陽極氧化膜厚度試驗法
9. CNS 771 烤漆檢驗法

鋼製密閉沖底型電纜線槽

STEEL VENTILATED THROUGH TYPE CABLE TRAY

INDEX

DESCRIPTION	PAGE
直式線槽 (STRAIGHT CABLE TRAY)	2
水平 L 形 90° 彎頭 (HORIZONTAL 90° ELBOW)	3
水平 L 形 60° 彎頭 (HORIZONTAL 60° ELBOW)	4
水平 L 形 45° 彎頭 (HORIZONTAL 45° ELBOW)	4
水平 L 形 30° 彎頭 (HORIZONTAL 30° ELBOW)	4
水平 T 形彎頭 (HORIZONTAL TEE ELBOW)	5
水平 X 形彎頭 (HORIZONTAL CROSS ELBOW)	6
垂直 T 形彎頭 (VERTICAL TEE ELBOW)	7
垂直上升 90° 彎頭 (VERTICAL INSIDE 90° ELBOW)	8
垂直上升 60° 彎頭 (VERTICAL INSIDE 60° ELBOW)	9
垂直上升 45° 彎頭 (VERTICAL INSIDE 45° ELBOW)	9
垂直上升 30° 彎頭 (VERTICAL INSIDE 30° ELBOW)	9
垂直下降 90° 彎頭 (VERTICAL OUTSIDE 90° ELBOW)	10
垂直下降 60° 彎頭 (VERTICAL OUTSIDE 60° ELBOW)	11
垂直下降 45° 彎頭 (VERTICAL OUTSIDE 45° ELBOW)	11
垂直下降 30° 彎頭 (VERTICAL OUTSIDE 30° ELBOW)	11
中間異徑接頭 (CENTER REDUCER ELBOW)	12
左偏異徑接頭 (LEFT REDUCER ELBOW)	13
右偏異徑接頭 (RIGHT REDUCER ELBOW)	14
線槽連接片 (STRAIGHT TRAY CONNECTOR)	15
配電盤連接片 (PANEL PLATE CONNECTOR)	15
水平可調連接片 (ADJUSTABLE HORIZONTAL CONNECTOR)	15
垂直可調連接片 (ADJUSTABLE VERTICAL CONNECTOR)	16
異徑連接片 (REDUCER PLATES)	16
終端封板 (BLIND END COVER)	16
蓋板固定夾 (COVER CLAMP)	17
外側固定片 (OUTSIDE HOLD DOWN CLAMP)	17
塑膠夾板 (PLASTIC CUP)	17
彈簧螺帽 (SPRING NUT)	18
全牙螺桿固定片 (THREADED ROD CLAMP)	18
全牙螺桿 (THREADED ROD)	18
接地銅片 (COPPER GROUNDING PIECES)	18
馬車螺絲 (SQUARE NECK BLOT)	18

直式線槽 (STRAIGHT CABLE TRAY)

(Units: mm)

寬(W)	高(H)	長(L)
100	100	3000
200		
300		
400		
500		
600		
700		
800		
900		
1000		

- 線槽材質：熱軋鋼板
- 線槽厚度：2.0mm±0.2mm
- 蓋板材質：熱軋鋼板
- 蓋板厚度：2.0mm±0.2mm
- 表面處理：熱浸鍍鋅
- 公差範圍：長(L)±3.0mm, 寬(W)±2.0mm, 高(H)±1.0mm
- TRAY MATERIAL : STEEL SHEET
- TRAY THICKNESS : 2.0mm±0.2mm
- COVER MATERIAL : STEEL SHEET
- COVER THICKNESS : 2.0mm±0.2mm
- FINISH : HOT DIPPED GALVANIZED AFTER FABRICATION
- TOLERANCE : Length±3.0mm, Width±2.0mm, High±1.0mm

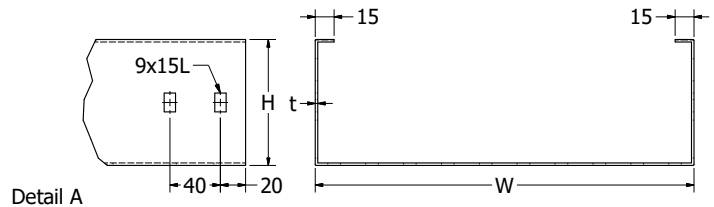
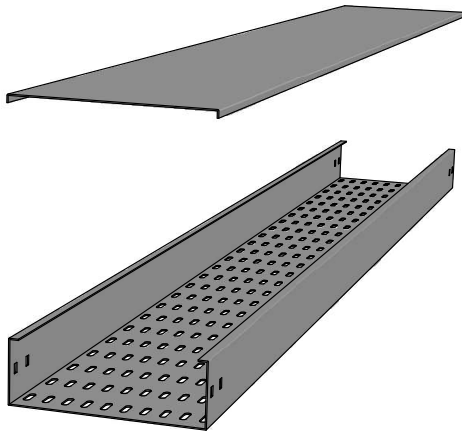

1 直式線槽蓋板 (STRAIGHT CABLE TRAY COVER)

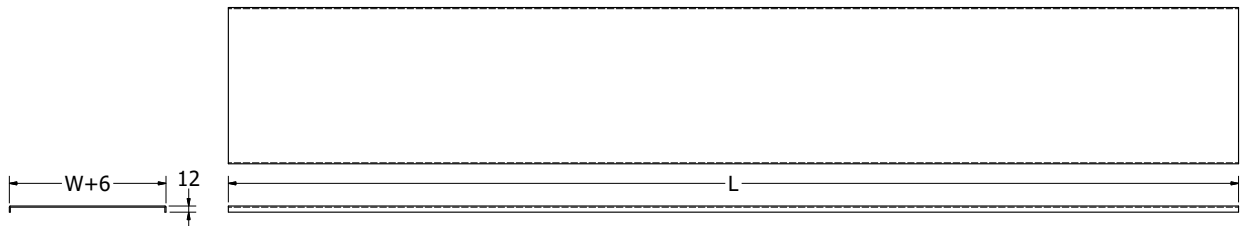

2 直式線槽 (STRAIGHT CABLE TRAY)

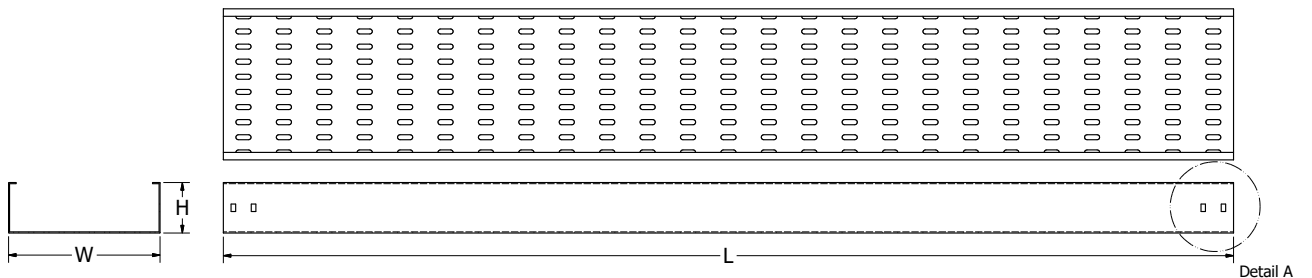

■ 水平 L 形 90° 彎頭 (HORIZONTAL 90° ELBOW)

(Units: mm)

寬(W)	高(H)	半徑(R)
100	100	120
200		
300		
400		
500		
600		
700		
800		
900		
1000		

- 線槽材質：熱軋鋼板
- 線槽厚度：2.0mm±0.2mm
- 蓋板材質：熱軋鋼板
- 蓋板厚度：2.0mm±0.2mm
- 表面處理：熱浸鍍鋅
- 公差範圍：長(L)±3.0mm, 寬(W)±2.0mm, 高(H)±1.0mm
- TRAY MATERIAL : STEEL SHEET
- TRAY THICKNESS : 2.0mm±0.2mm
- COVER MATERIAL : STEEL SHEET
- COVER THICKNESS : 2.0mm±0.2mm
- FINISH : HOT DIPPED GALVANIZED AFTER FABRICATION
- TOLERANCE : Length±3.0mm, Width±2.0mm, High±1.0mm

1 水平 L 形 90° 彎頭 (HORIZONTAL 90° ELBOW)

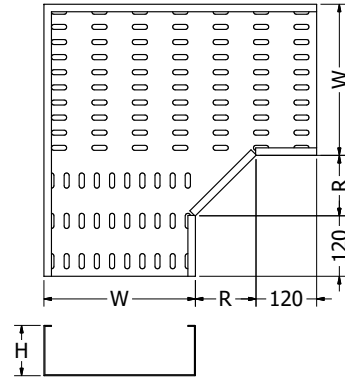
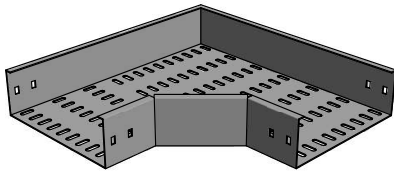

2 水平 L 形 90° 彎頭蓋板 (HORIZONTAL 90° ELBOW COVER)

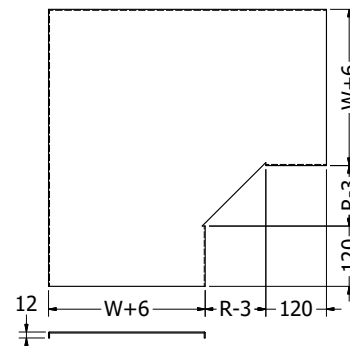
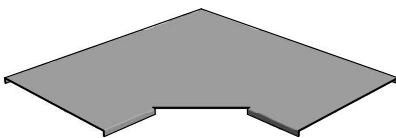

■ 水平 L 形 (60°, (45°), (30°) 彎頭 (HORIZONTAL 60°,45°,30° ELBOW)

(Units: mm)

寬(W)	高(H)	半徑(R)	角度(θ)
100	100	120	60
200			
300			
400			
500			
600			
700			
800			
900			
1000			

- 線槽材質：熱軋鋼板
- 線槽厚度：2.0mm±0.2mm
- 蓋板材質：熱軋鋼板
- 蓋板厚度：2.0mm±0.2mm
- 表面處理：熱浸鍍鋅
- 公差範圍：長(L)±3.0mm, 寬(W)±2.0mm, 高(H)±1.0mm
- TRAY MATERIAL : STEEL SHEET
- TRAY THICKNESS : 2.0mm±0.2mm
- COVER MATERIAL : STEEL SHEET
- COVER THICKNESS : 2.0mm±0.2mm
- FINISH : HOT DIPPED GALVANIZED AFTER FABRICATION
- TOLERANCE : Length±3.0mm, Width±2.0mm, High±1.0mm

1 水平 L 形 (60°, (45°), (30°) 彎頭 (HORIZONTAL 60°,45°,30° ELBOW)

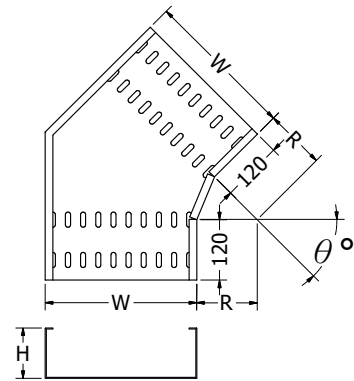
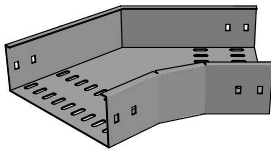

2 水平 L 形 (60°, (45°), (30°) 彎頭蓋板 (HORIZONTAL 60°,45°,30° ELBOW COVER)

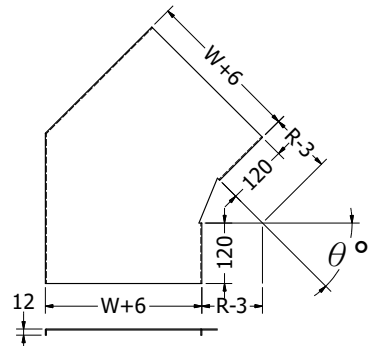
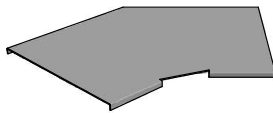

■ 水平 T 形彎頭 (HORIZONTAL TEE ELBOW)

(Units: mm)

寬(W)	高(H)	半徑(R)
100	100	120
200		
300		
400		
500		
600		
700		
800		
900		
1000		

- 線槽材質：熱軋鋼板
- 線槽厚度：2.0mm±0.2mm
- 蓋板材質：熱軋鋼板
- 蓋板厚度：2.0mm±0.2mm
- 表面處理：熱浸鍍鋅
- 公差範圍：長(L)±3.0mm, 寬(W)±2.0mm, 高(H)±1.0mm
- TRAY MATERIAL : STEEL SHEET
- TRAY THICKNESS : 2.0mm±0.2mm
- COVER MATERIAL : STEEL SHEET
- COVER THICKNESS : 2.0mm±0.2mm
- FINISH : HOT DIPPED GALVANIZED AFTER FABRICATION
- TOLERANCE : Length±3.0mm, Width±2.0mm, High±1.0mm

1 水平 T 形彎頭 (HORIZONTAL TEE ELBOW)

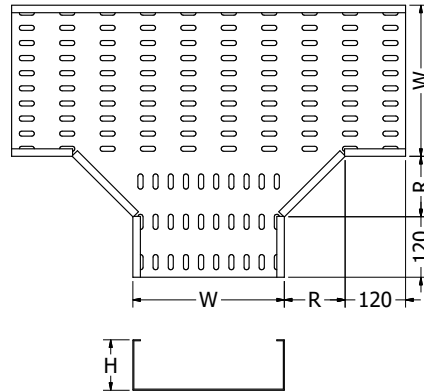
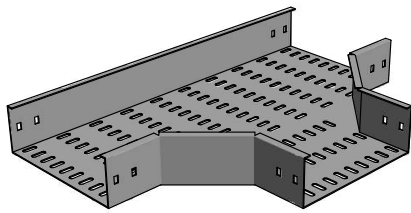

2 水平 T 形彎頭蓋板 (HORIZONTAL TEE ELBOW COVER)

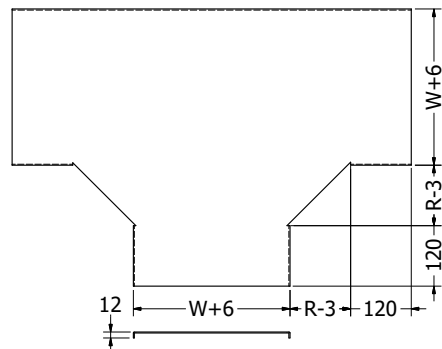
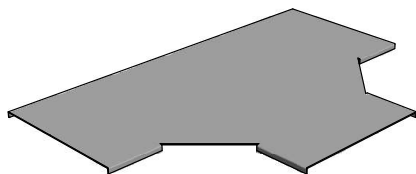

水平 X 形彎頭 (HORIZONTAL CROSS ELBOW)

(Units: mm)

寬(W)	高(H)	半徑(R)
100	100	120
200		
300		
400		
500		
600		
700		
800		
900		
1000		

- 線槽材質：熱軋鋼板
- 線槽厚度：2.0mm±0.2mm
- 蓋板材質：熱軋鋼板
- 蓋板厚度：2.0mm±0.2mm
- 表面處理：熱浸鍍鋅
- 公差範圍：長(L)±3.0mm, 寬(W)±2.0mm, 高(H)±1.0mm
- TRAY MATERIAL : STEEL SHEET
- TRAY THICKNESS : 2.0mm±0.2mm
- COVER MATERIAL : STEEL SHEET
- COVER THICKNESS : 2.0mm±0.2mm
- FINISH : HOT DIPPED GALVANIZED AFTER FABRICATION
- TOLERANCE : Length±3.0mm, Width±2.0mm, High±1.0mm

1 水平 X 形彎頭 (HORIZONTAL CROSS ELBOW)

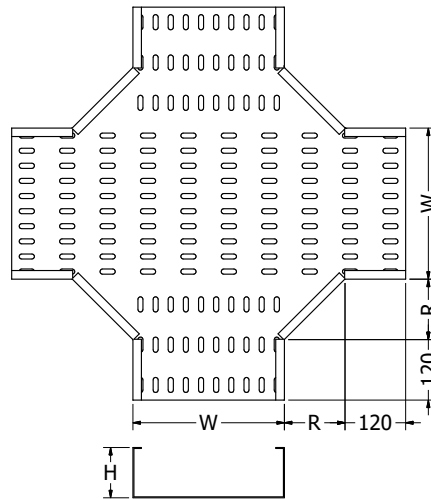
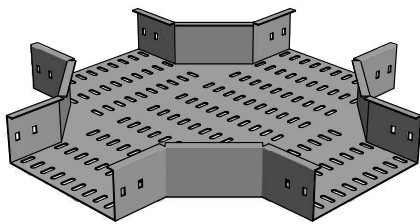

2 水平 X 形彎頭蓋板 (HORIZONTAL CROSS ELBOW COVER)

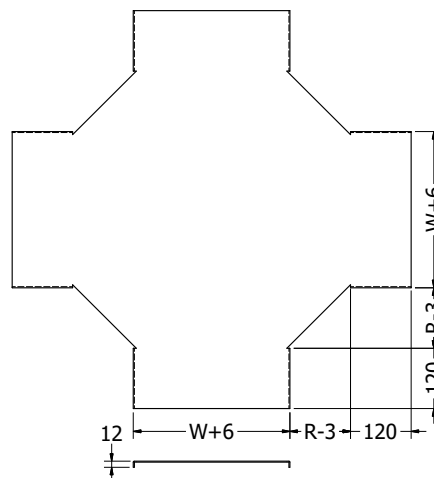
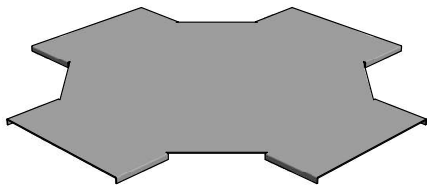

垂直 T 形彎頭 (VERTICAL TEE ELBOW)

(Units: mm)

寬(W)	高(H)	半徑(R)
100	100	120
200		
300		
400		
500		
600		
700		
800		
900		
1000		

- 線槽材質：熱軋鋼板
- 線槽厚度：2.0mm±0.2mm
- 蓋板材質：熱軋鋼板
- 蓋板厚度：2.0mm±0.2mm
- 表面處理：熱浸鍍鋅
- 公差範圍：長(L)±3.0mm, 寬(W)±2.0mm, 高(H)±1.0mm
- TRAY MATERIAL : STEEL SHEET
- TRAY THICKNESS : 2.0mm±0.2mm
- COVER MATERIAL : STEEL SHEET
- COVER THICKNESS : 2.0mm±0.2mm
- FINISH : HOT DIPPED GALVANIZED AFTER FABRICATION
- TOLERANCE : Length±3.0mm, Width±2.0mm, High±1.0mm

1 垂直 T 形彎頭 (VERTICAL TEE ELBOW)

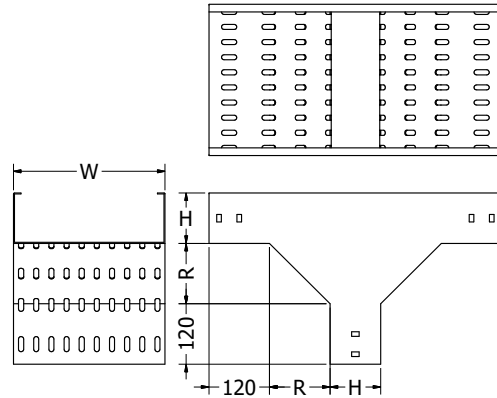
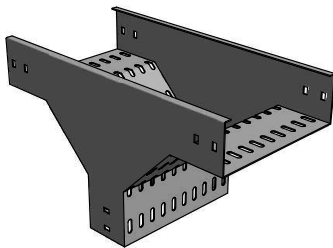

2 垂直 T 形彎頭蓋板 (VERTICAL TEE ELBOW COVER)

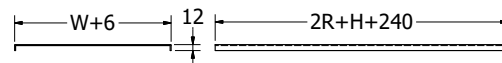
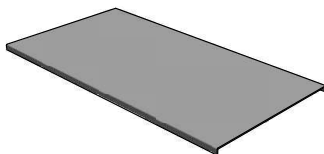

■ 垂直上升90° 彎頭 (VERTICAL INSIDE 90° ELBOW)

(Units: mm)

寬(W)	高(H)	半徑(R)
100	100	120
200		
300		
400		
500		
600		
700		
800		
900		
1000		

- 線槽材質：熱軋鋼板
- 線槽厚度：2.0mm±0.2mm
- 蓋板材質：熱軋鋼板
- 蓋板厚度：2.0mm±0.2mm
- 表面處理：熱浸鍍鋅
- 公差範圍：長(L)±3.0mm, 寬(W)±2.0mm, 高(H)±1.0mm
- TRAY MATERIAL : STEEL SHEET
- TRAY THICKNESS : 2.0mm±0.2mm
- COVER MATERIAL : STEEL SHEET
- COVER THICKNESS : 2.0mm±0.2mm
- FINISH : HOT DIPPED GALVANIZED AFTER FABRICATION
- TOLERANCE : Length±3.0mm, Width±2.0mm, High±1.0mm

1 垂直上升90° 彎頭 (VERTICAL INSIDE 90° ELBOW)

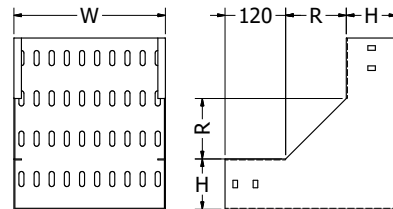
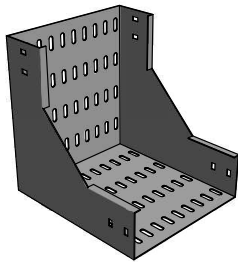

2 垂直上升90° 彎頭蓋板 (VERTICAL INSIDE 90° ELBOW COVER)

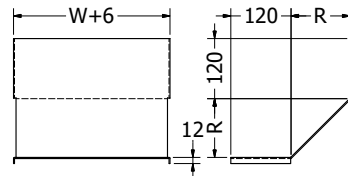
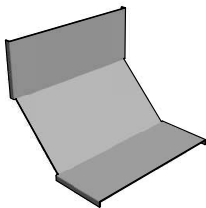

■ 垂直上升(60°), (45°), (30°) 彎頭 (VERTICAL INSIDE 60°,45°,30° ELBOW)

(Units: mm)

寬(W)	高(H)	半徑(R)	角度(θ)
100	100	120	60
200			
300			
400			
500			
600			
700			
800			
900			
1000			

- 線槽材質：熱軋鋼板
- 線槽厚度：2.0mm±0.2mm
- 蓋板材質：熱軋鋼板
- 蓋板厚度：2.0mm±0.2mm
- 表面處理：熱浸鍍鋅
- 公差範圍：長(L)±3.0mm, 寬(W)±2.0mm, 高(H)±1.0mm
- TRAY MATERIAL : STEEL SHEET
- TRAY THICKNESS : 2.0mm±0.2mm
- COVER MATERIAL : STEEL SHEET
- COVER THICKNESS : 2.0mm±0.2mm
- FINISH : HOT DIPPED GALVANIZED AFTER FABRICATION
- TOLERANCE : Length±3.0mm, Width±2.0mm, High±1.0mm

1 垂直上升(60°),(45°),(30°) 彎頭 (VERTICAL INSIDE 60°,45°,30° ELBOW)

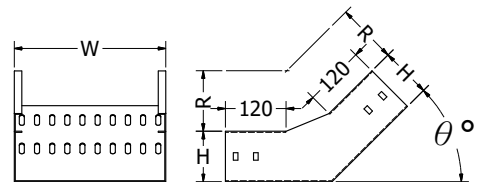
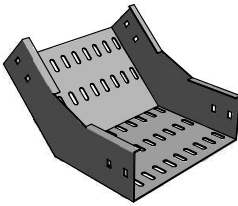

2 垂直上升(60°), (45°), (30°) 彎頭蓋板 (VERTICAL INSIDE 60°,45°,30° ELBOW COVER)

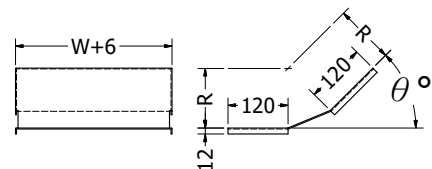
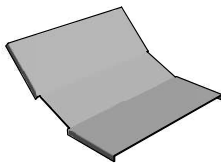

■ 垂直下降90° 彎頭 (VERTICAL OUTSIDE 90° ELBOW)

(Units: mm)

寬(W)	高(H)	半徑(R)
100	100	120
200		
300		
400		
500		
600		
700		
800		
900		
1000		

- 線槽材質：熱軋鋼板
- 線槽厚度：2.0mm±0.2mm
- 蓋板材質：熱軋鋼板
- 蓋板厚度：2.0mm±0.2mm
- 表面處理：熱浸鍍鋅
- 公差範圍：長(L)±3.0mm, 寬(W)±2.0mm, 高(H)±1.0mm
- TRAY MATERIAL : STEEL SHEET
- TRAY THICKNESS : 2.0mm±0.2mm
- COVER MATERIAL : STEEL SHEET
- COVER THICKNESS : 2.0mm±0.2mm
- FINISH : HOT DIPPED GALVANIZED AFTER FABRICATION
- TOLERANCE : Length±3.0mm, Width±2.0mm, High±1.0mm

1 垂直下降90° 彎頭 (VERTICAL OUTSIDE 90° ELBOW)

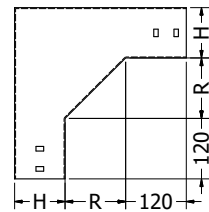
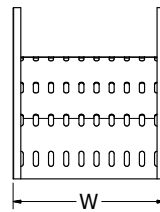
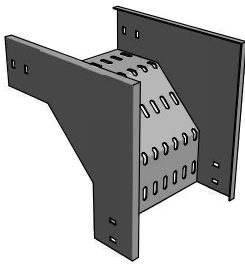

2 垂直下降90° 彎頭蓋板 (VERTICAL OUTSIDE 90° ELBOW COVER)

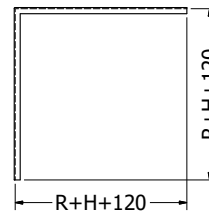
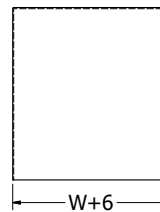
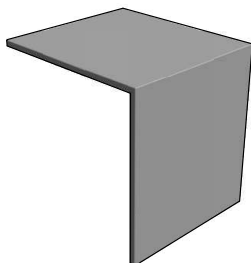

■ 垂直下降(60°), (45°), (30°) 彎頭 (VERTICAL OUTSIDE 60°,45°,30° ELBOW)

(Units: mm)

寬(W)	高(H)	半徑(R)	角度(θ)
100	100	120	60
200			
300			
400			
500			
600			
700			
800			
900			
1000			

- 線槽材質：熱軋鋼板
- 線槽厚度：2.0mm±0.2mm
- 蓋板材質：熱軋鋼板
- 蓋板厚度：2.0mm±0.2mm
- 表面處理：熱浸鍍鋅
- 公差範圍：長(L)±3.0mm, 寬(W)±2.0mm, 高(H)±1.0mm
- TRAY MATERIAL : STEEL SHEET
- TRAY THICKNESS : 2.0mm±0.2mm
- COVER MATERIAL : STEEL SHEET
- COVER THICKNESS : 2.0mm±0.2mm
- FINISH : HOT DIPPED GALVANIZED AFTER FABRICATION
- TOLERANCE : Length±3.0mm, Width±2.0mm, High±1.0mm

1 垂直下降(60°),(45°),(30°) 彎頭 (VERTICAL OUTSIDE 60°,45°,30° ELBOW)

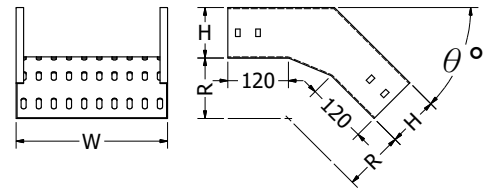
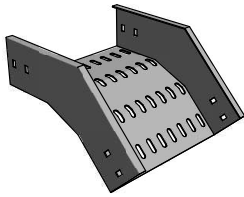

2 垂直下降(60°), (45°), (30°) 彎頭蓋板 (VERTICAL OUTSIDE 60°,45°,30° ELBOW COVER)

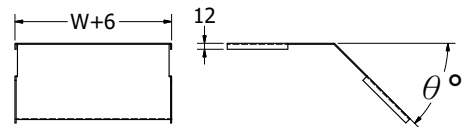
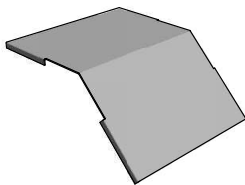

中間異徑接頭 (CENTER REDUCER ELBOW)

(Units:mm)

1 中間異徑接頭 (CENTER REDUCER ELBOW)

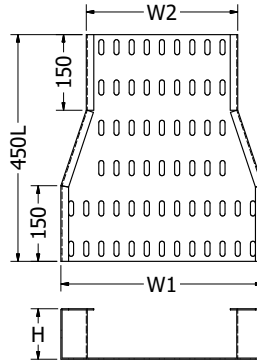
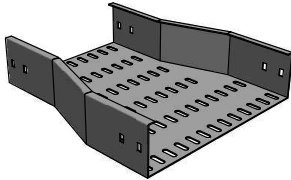

2 中間異徑接頭蓋板 (CENTER REDUCER ELBOW COVER)

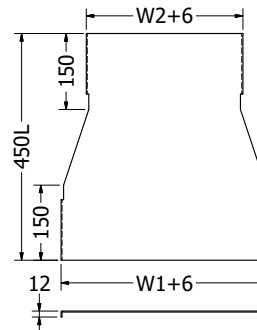
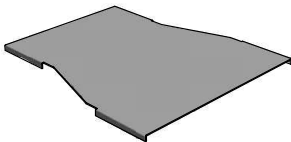

寬(W1)	寬(W2)	高(H)
200	100	100
300	100	
	200	
400	100	
	200	
	300	
500	100	
	200	
	300	
	400	
600	100	
	200	
	300	
	400	
	500	
700	100	
	200	
	300	
	400	
	500	
	600	
800	100	
	200	
	300	
	400	
	500	
	600	
	700	
900	100	
	200	
	300	
	400	
	500	
	600	
	700	
	800	
1000	100	
	200	
	300	
	400	
	500	
	600	
	700	
	800	
	900	

- 線槽材質：熱軋鋼板
- 線槽厚度：2.0mm±0.2mm
- 蓋板材質：熱軋鋼板
- 蓋板厚度：2.0mm±0.2mm
- 表面處理：熱浸鍍鋅
- 公差範圍：長(L)±3.0mm, 寬(W)±2.0mm, 高(H)±1.0mm

- TRAY MATERIAL : STEEL SHEET
- TRAY THICKNESS : 2.0mm±0.2mm
- COVER MATERIAL : STEEL SHEET
- COVER THICKNESS : 2.0mm±0.2mm
- FINISH : HOT DIPPED GALVANIZED AFTER FABRICATION
- TOLERANCE : Length±3.0mm, Width±2.0mm, High±1.0mm

左偏異徑接頭 (LEFT REDUCER ELBOW)

(Units:mm)

1 左偏異徑接頭 (LEFT REDUCER ELBOW)

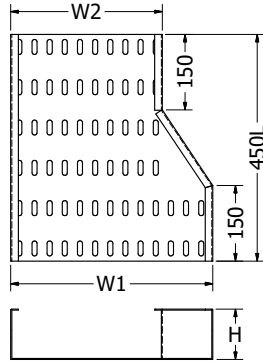
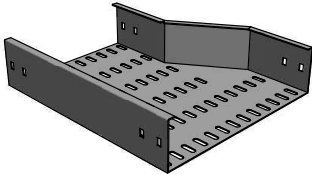

2 左偏異徑接頭蓋板 (LEFT REDUCER ELBOW COVER)

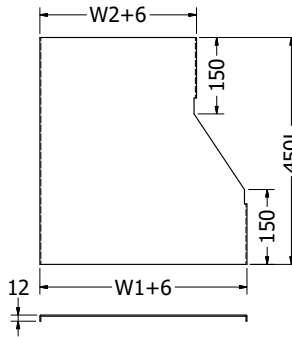
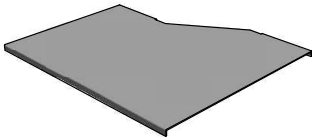

- 線槽材質：熱軋鋼板
- 線槽厚度：2.0mm±0.2mm
- 蓋板材質：熱軋鋼板
- 蓋板厚度：2.0mm±0.2mm
- 表面處理：熱浸鍍鋅
- 公差範圍：長(L)±3.0mm, 寬(W)±2.0mm, 高(H)±1.0mm

- TRAY MATERIAL : STEEL SHEET
- TRAY THICKNESS : 2.0mm±0.2mm
- COVER MATERIAL : STEEL SHEET
- COVER THICKNESS : 2.0mm±0.2mm
- FINISH : HOT DIPPED GALVANIZED AFTER FABRICATION
- TOLERANCE : Length±3.0mm, Width±2.0mm, High±1.0mm

寬(W1)	寬(W2)	高(H)
200	100	100
300	100	
	200	
400	100	
	200	
	300	
500	100	
	200	
	300	
	400	
600	100	
	200	
	300	
	400	
	500	
700	100	
	200	
	300	
	400	
	500	
	600	
800	100	
	200	
	300	
	400	
	500	
	600	
	700	
900	100	
	200	
	300	
	400	
	500	
	600	
	700	
	800	
1000	100	
	200	
	300	
	400	
	500	
	600	
	700	
	800	
	900	

右偏異徑接頭 (RIGHT REDUCER ELBOW)

(Units:mm)

1 右偏異徑接頭 (RIGHT REDUCER ELBOW)

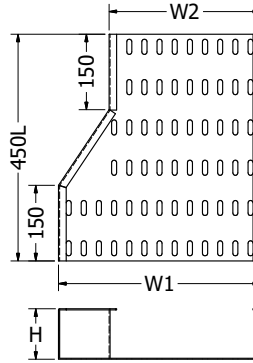
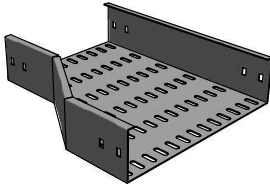

2 右偏異徑接頭蓋板 (RIGHT REDUCER ELBOW COVER)

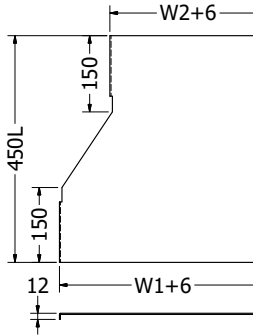
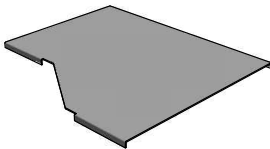

- 線槽材質：熱軋鋼板
- 線槽厚度：2.0mm±0.2mm
- 蓋板材質：熱軋鋼板
- 蓋板厚度：2.0mm±0.2mm
- 表面處理：熱浸鍍鋅
- 公差範圍：長(L)±3.0mm, 寬(W)±2.0mm, 高(H)±1.0mm

- TRAY MATERIAL : STEEL SHEET
- TRAY THICKNESS : 2.0mm±0.2mm
- COVER MATERIAL : STEEL SHEET
- COVER THICKNESS : 2.0mm±0.2mm
- FINISH : HOT DIPPED GALVANIZED AFTER FABRICATION
- TOLERANCE : Length±3.0mm, Width±2.0mm, High±1.0mm

寬(W1)	寬(W2)	高(H)
200	100	100
300	100	
	200	
400	100	
	200	
	300	
500	100	
	200	
	300	
	400	
600	100	
	200	
	300	
	400	
	500	
700	100	
	200	
	300	
	400	
	500	
	600	
800	100	
	200	
	300	
	400	
	500	
	600	
	700	
900	100	
	200	
	300	
	400	
	500	
	600	
	700	
	800	
1000	100	
	200	
	300	
	400	
	500	
	600	
	700	
	800	
	900	

- 線槽連接片 (STRAIGHT TRAY CONNECTOR)
- 配電盤連接片 (PANEL PLATE CONNECTOR)
- 水平可調連接片 (ADJUSTABLE HORIZONTAL CONNECTOR)

1 線槽連接片 (STRAIGHT TRAY CONNECTOR)

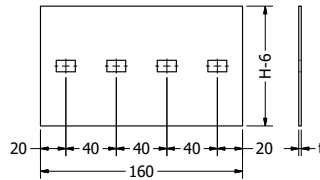
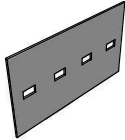

- 材 質：熱軋鋼板
- 厚 度：2.0mm±0.2mm
- 表面處理：熱浸鍍鋅

- MATERIAL : STEEL SHEET
- THICKNESS : 2.0mm±0.2mm
- FINISH : HOT DIPPED GALVANIZED AFTER FABRICATION

2 配電盤連接片 (PANEL PLATE CONNECTOR)

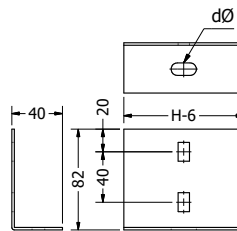
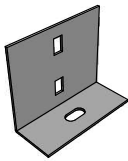

- 材 質：熱軋鋼板
- 厚 度：2.0mm±0.2mm
- 表面處理：熱浸鍍鋅

- MATERIAL : STEEL SHEET
- THICKNESS : 2.0mm±0.2mm
- FINISH : HOT DIPPED GALVANIZED AFTER FABRICATION

3 水平可調連接片 (ADJUSTABLE HORIZONTAL CONNECTOR)

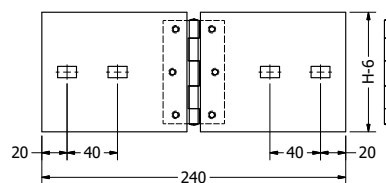
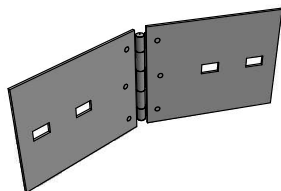

- 材 質：熱軋鋼板
- 厚 度：2.0mm±0.2mm
- 表面處理：熱浸鍍鋅

- MATERIAL : STEEL SHEET
- THICKNESS : 2.0mm±0.2mm
- FINISH : HOT DIPPED GALVANIZED AFTER FABRICATION

■ 垂直可調連接片 (ADJUSTABLE VERTICAL CONNECTOR)

■ 異徑連接片 (REDUCER PLATES)

■ 終端封板 (BLIND END COVER)

1 垂直可調連接片 (ADJUSTABLE VERTICAL CONNECTOR)

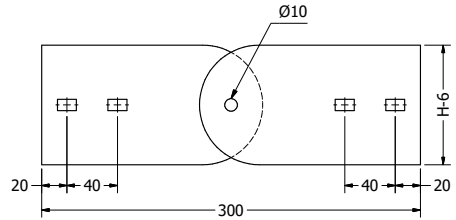
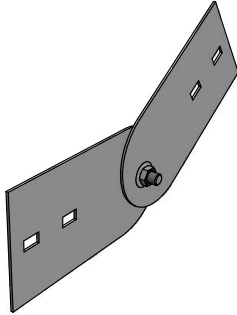

- 材 質：熱軋鋼板
- 厚 度：2.0mm±0.2mm
- 表面處理：熱浸鍍鋅

- MATERIAL : STEEL SHEET
- THICKNESS : 2.0mm±0.2mm
- FINISH : HOT DIPPED GALVANIZED AFTER FABRICATION

2 異徑連接片 (REDUCER PLATES)

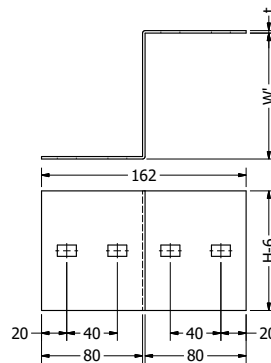
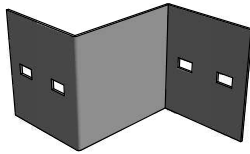

- 材 質：熱軋鋼板
- 厚 度：2.0mm±0.2mm
- 表面處理：熱浸鍍鋅

- MATERIAL : STEEL SHEET
- THICKNESS : 2.0mm±0.2mm
- FINISH : HOT DIPPED GALVANIZED AFTER FABRICATION

3 終端封板 (BLIND END COVER)

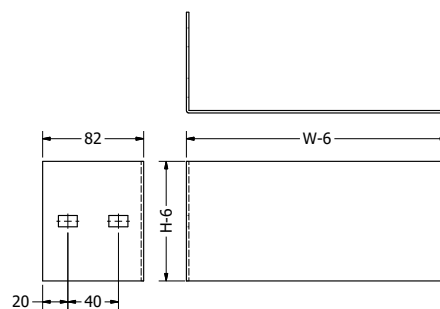
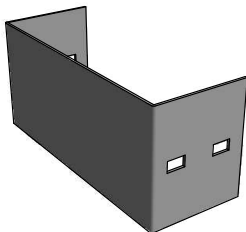

- 材 質：熱軋鋼板
- 厚 度：2.0mm±0.2mm
- 表面處理：熱浸鍍鋅

- MATERIAL : STEEL SHEET
- THICKNESS : 2.0mm±0.2mm
- FINISH : HOT DIPPED GALVANIZED AFTER FABRICATION

- 蓋板固定夾 (COVER CLAMP)
- 外側固定片 (OUTSIDE HOLD DOWN CLAMP)
- 塑膠夾板 (PLASTIC CUP)

1 蓋板固定夾 (COVER CLAMP)

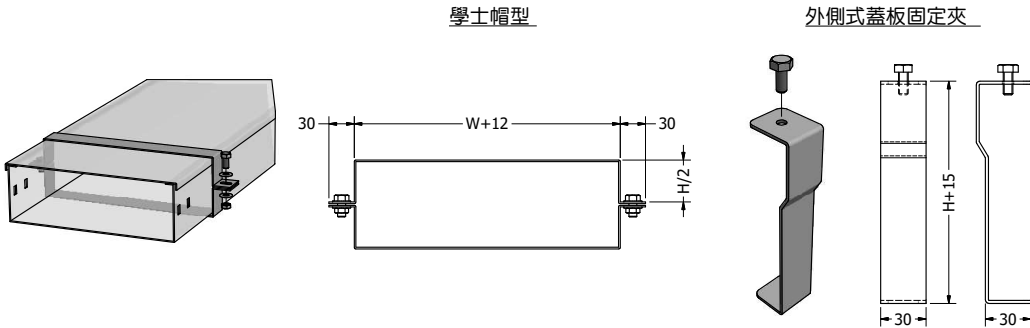

寬(W)	高(H)
100	100
200	
300	
400	
500	
600	
700	
800	
900	
1000	

- 材 質：熱軋鋼板
- 厚 度：2.0mm±0.2mm
- 表面處理：熱浸鍍鋅

- MATERIAL : STEEL SHEET
- THICKNESS : 2.0mm±0.2mm
- FINISH : HOT DIPPED GALVANIZED AFTER FABRICATION

2 外側固定片 (OUTSIDE HOLD DOWN CLAMP)

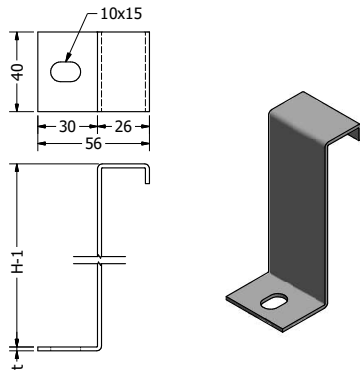

外側固定片安裝示意圖

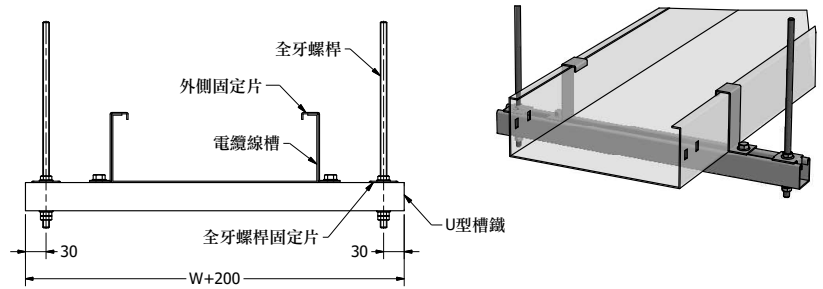

- 材 質：熱軋鋼板
- 厚 度：2.0mm±0.2mm
- 表面處理：熱浸鍍鋅

- MATERIAL : STEEL SHEET
- THICKNESS : 2.0mm±0.2mm
- FINISH : HOT DIPPED GALVANIZED AFTER FABRICATION

3 塑膠夾板 (PLASTIC CUP)

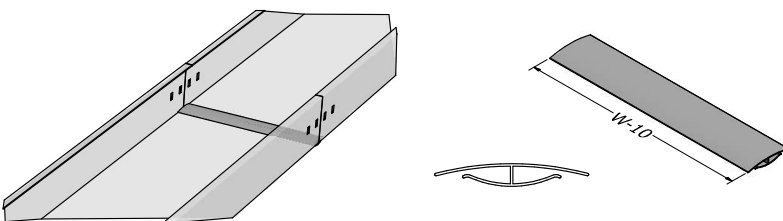

寬(W)
100
200
300
400
500
600
700
800
900
1000

- 材 質：塑膠
- FINISH : PLASTIC

- 彈簧螺帽 (SPRING NUT)
- 全牙螺桿固定片 (THREADED ROD CLAMP)
- 接地銅片 (COPPER GROUNDING PIECES)
- 全牙螺桿 (THREADED ROD)
- 馬車螺絲 (SQUARE NECK BLOT)

1 彈簧螺帽 (SPRING NUT)

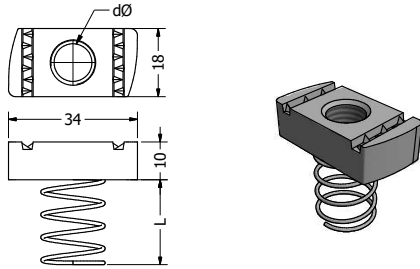

- 材 質：可鍛鑄鐵
- 表面處理：電鍍鋅
- 尺 寸：1/2"
- MATERIAL : MALLEABLE STEEL IRON
- FINISH : ELECTRO GALVANIZED
- DIMENSION : 1/2"

2 全牙螺桿固定片 (THREADED ROD CLAMP)

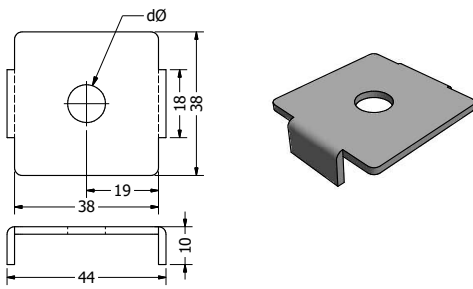

- 材 質：熱軋鋼板
- 厚 度：2.0mm±0.2mm
- 表面處理：熱浸鍍鋅
- MATERIAL : STEEL SHEET
- THICKNESS : 2.0mm±0.2mm
- FINISH : HOT DIPPED GALVANIZED AFTER FABRICATION

4 全牙螺桿 (THREADED ROD)

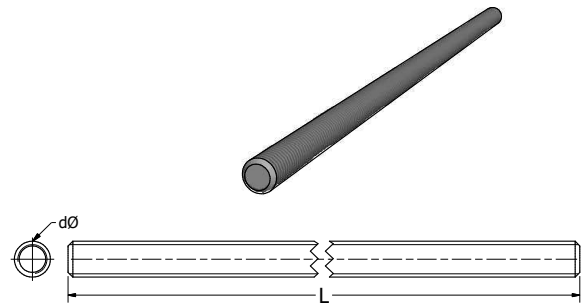

- 材 質：鐵
- 表面處理：電鍍鋅
- 尺 寸：1/2"
- MATERIAL : IRON
- FINISH : ELECTRO GALVANIZED
- DIMENSION : 1/2"

3 接地銅片 (COPPER GROUNDING PIECES)

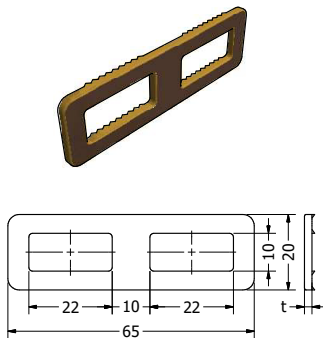

- 材 質：銅
- 厚 度：2.0mm±0.2mm
- MATERIAL : COPPER
- THICKNESS : 2.0mm±0.2mm

5 馬車螺絲 (SQUARE NECK BLOT)

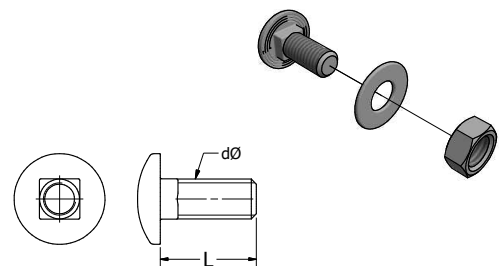

- 材 質：不銹鋼 SUS304
- 尺 寸：5/16 ϕ x 3/4"L
- MATERIAL : STAINLESS STEEL SUS304
- DIMENSION : 5/16 ϕ x 3/4"L