

(鋁製)燈槽
Aluminum Raceway

欣歐企業股份有限公司
SENCO ENTERPRISE CO., LTD.

831 高雄市大寮區光華路 470 巷 138 號
電話: (07)788-6336
傳真: (07)788-6339

No.138, Lane 470, Guanghua Rd., Daliao District,
Kaohsiung City 831, Taiwan.

website: www.senco.com.tw
e-mail: senco@ms18.hinet.net



電纜線槽製造標準

一. 製造標準

1. CNS 13303 C4466 金屬電纜線架系統
2. NEMA VE1-1996 METALLIC CABLE TRAY SYSTEMS

二. 材料標準

1. CNS 1244 熱浸法鍍鋅鋼片
2. CNS 10804 烤漆熱浸鍍鋅鋼片及鋼捲
3. CNS 2068 鋁及鋁合金之合金種類及鍊度符號
4. CNS 2253 鋁及鋁合金之片及板
5. CNS 2257 鋁擠型條
6. CNS 8499 冷軋不銹鋼鋼片及鋼板

三. 表面處理標準

1. CNS 8590 鋁及鋁合金之硫酸陽極氧化處理作業
2. CNS 8507 鋁及鋁合金之陽極氧化皮膜
3. CNS 10007 鋼鐵之熱浸法鍍鋅
4. CNS 770 烤漆
5. CNS 4938 環氧樹脂漆

四. 檢驗標準

1. CNS 13303 C4466 金屬電纜線架系統
2. NEMA VE1-1996 METALLIC CABLE TRAY SYSTEMS
3. CNS 2608 鋼料之檢驗通則
4. CNS 1247 熱浸法鍍鋅鋼片檢驗法
5. CNS 8500 冷軋不銹鋼鋼片及鋼板檢驗法
6. CNS 2258 鋁擠型條檢驗法
7. CNS 2254 鋁及鋁合金之片及板檢驗法
8. CNS 8406 鋁及鋁合金之陽極氧化膜厚度試驗法
9. CNS 771 烤漆檢驗法

(鋁製)燈槽
ALUMINUM RACEWAY

INDEX

DESCRIPTION	PAGE
直式燈槽 (STRAIGHT RACEWAY)	2
水平 L 形 90° 彎頭 (HORIZONTAL 90° ELBOW)	2
水平 L 形 45° 彎頭 (HORIZONTAL 45° ELBOW)	2
水平 T 形彎頭 (HORIZONTAL TEE ELBOW)	3
水平 X 形彎頭 (HORIZONTAL CROSS ELBOW)	3
垂直上升 90° 彎頭 (VERTICAL INSIDE 90° ELBOW)	4
垂直上升 45° 彎頭 (VERTICAL INSIDE 45° ELBOW)	4
垂直下降 90° 彎頭 (VERTICAL OUTSIDE 90° ELBOW)	4
垂直下降 45° 彎頭 (VERTICAL OUTSIDE 45° ELBOW)	4
燈槽連接片 (CONNECTOR)	5
終端封板 (BLIND END COVER)	5
配電盤連接片 (PANEL PLATE CONNECTOR)	5
門型吊環 (HANGER CLAMP)	5
燈具吊夾 (LIGHTING CLAMP)	6
彎頭蓋板固定夾 (ELBOW COVER CLAMP)	6
馬車螺絲 (SQUARE NECK BLOT)	6

- 直式燈槽 (STRAIGHT RACEWAY)
- 水平 L型 90° 彎頭 (HORIZONTAL 90° ELBOW)
- 水平 L型 45° 彎頭 (HORIZONTAL 45° ELBOW)

1 直式燈槽 (STRAIGHT RACEWAY)

(Units: mm)

寬(W)	高(H)	長(L)	燈槽	蓋板
50	50	3000	1.6t	1.2t
100				1.6t
100	60		2.0t	1.2t
150				1.2t
100	100		1.6t	

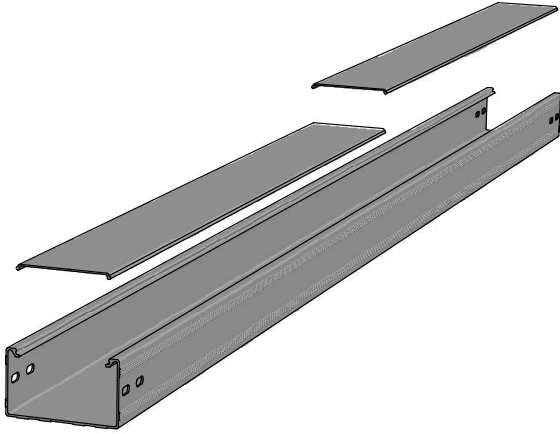

- 燈槽材質: 鋁合金 6063-T5
- 蓋板材質: 鋁合金 6063-T5
- 表面處理: 陽極處理
- 公差範圍: 長(L)±3.0mm, 寬(W)±2.0mm, 高(H)±1.0mm
厚度(t)±0.2mm

- TRAY MATERIAL : ALUMINUM ALLOYS 6063-T5
- COVER MATERIAL : ALUMINUM ALLOYS 6063-T5
- FINISH: ALUMINUM ANODIC TREATMENT

- TOLERANCE: Length±3.0mm, Width±2.0mm, Height±1.0mm
Thickness±0.2mm

註: 蓋板長度 1500L

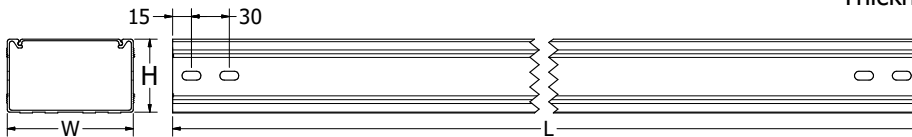

2 水平 L形 90° 彎頭 (HORIZONTAL 90° ELBOW)

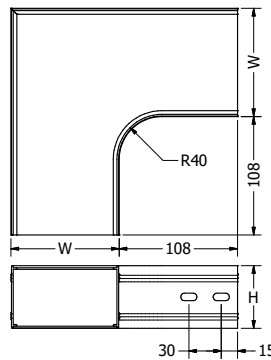
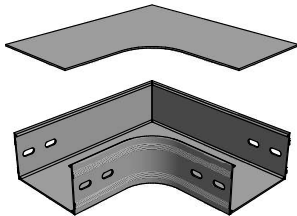

燈槽本體

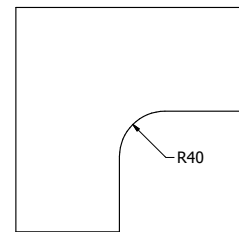

燈槽蓋板

3 水平 L形 45° 彎頭 (HORIZONTAL 45° ELBOW)

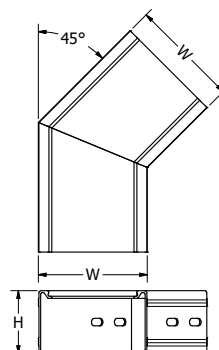
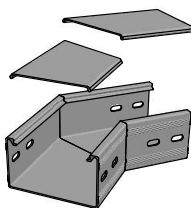

燈槽本體

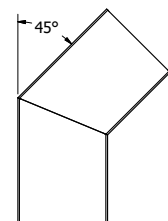

燈槽蓋板

- 水平 T形彎頭 (HORIZONTAL TEE ELBOW)
- 水平 X型彎頭 (HORIZONTAL CROSS ELBOW)

1 水平 T形彎頭 (HORIZONTAL TEE ELBOW)

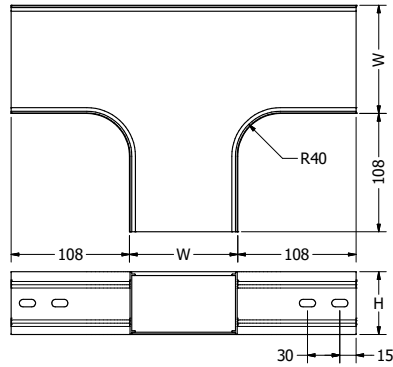
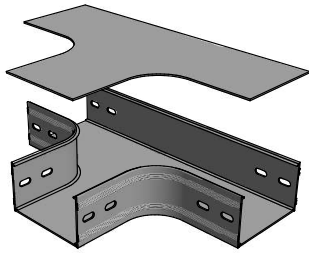

燈槽本體

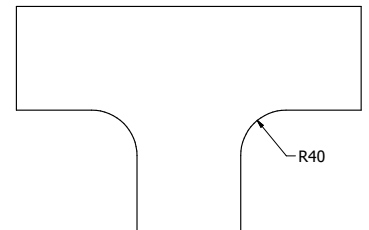

燈槽蓋板

2 水平 X形彎頭 (HORIZONTAL CROSS ELBOW)

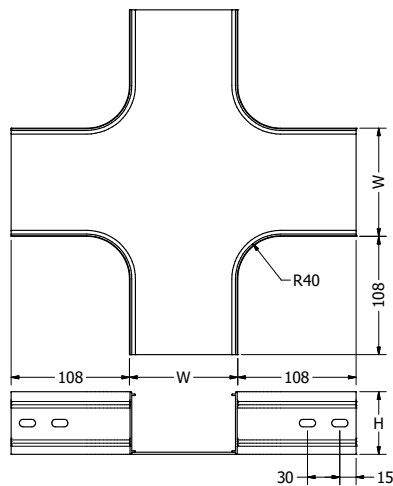
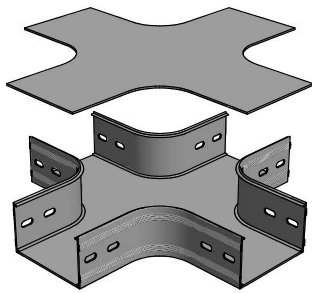

燈槽本體

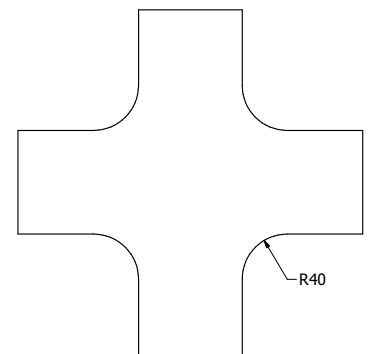

燈槽蓋板

- 垂直上升 90° 彎頭 (VERTICAL INSIDE 90° ELBOW)
- 垂直上升 45° 彎頭 (VERTICAL INSIDE 45° ELBOW)
- 垂直下降 90° 彎頭 (VERTICAL OUTSIDE 90° ELBOW)
- 垂直下降 45° 彎頭 (VERTICAL OUTSIDE 45° ELBOW)

1 垂直上升 90° 彎頭 (VERTICAL INSIDE 90° ELBOW)

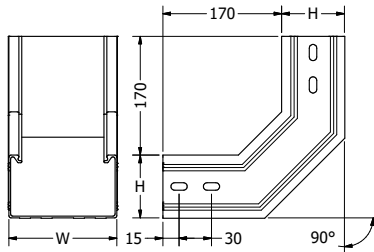
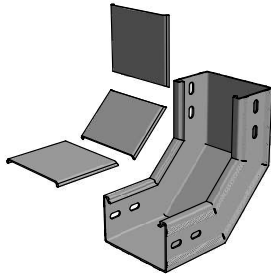

燈槽本體

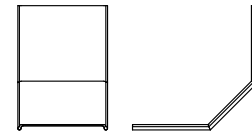

燈槽蓋板

2 垂直上升 45° 彎頭 (VERTICAL INSIDE 45° ELBOW)

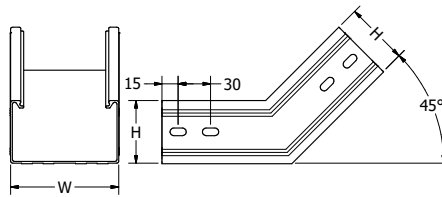
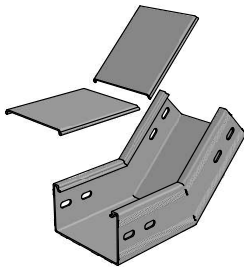

燈槽本體



燈槽蓋板

3 垂直下降 90° 彎頭 (VERTICAL OUTSIDE 90° ELBOW)

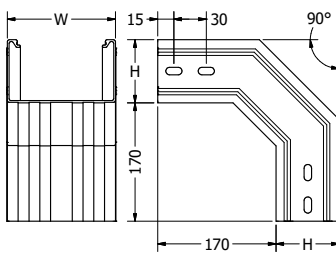
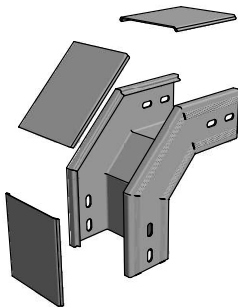

燈槽本體

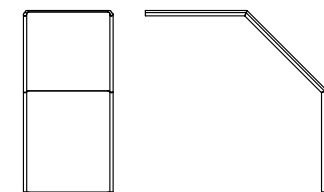

燈槽蓋板

4 垂直下降 45° 彎頭 (VERTICAL OUTSIDE 45° ELBOW)

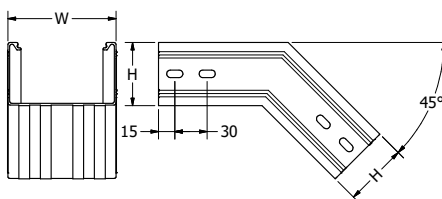
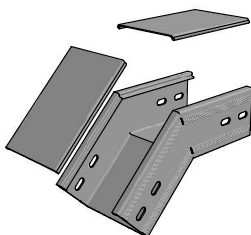

燈槽本體

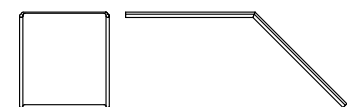

燈槽蓋板

- 燈槽連接片 (CONNECTOR)
- 終端封板 (BLIND END COVER)
- 配電盤連接片 (PANEL PLATE CONNECTOR)
- 門型吊環 (HANGER CLAMP)

1 燈槽連接片 (CONNECTOR)

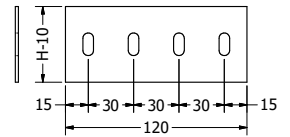
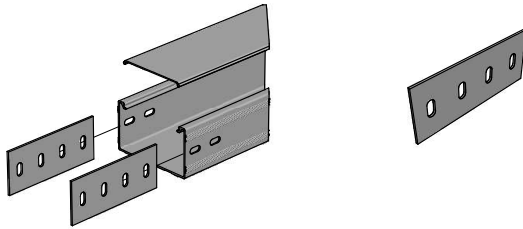

- 材 質: 鋁板 1050
- 厚 度: 2.0mm±0.2mm
- 表面處理: 陽極處理
- MATERIAL: ALUMINUM SHEET 1050
- THICKNESS: 2.0mm±0.2mm
- FINISH: ALUMINUM ANODIC TREATMENT

2 終端封板 (BLIND END COVER)

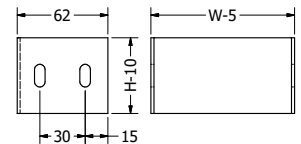
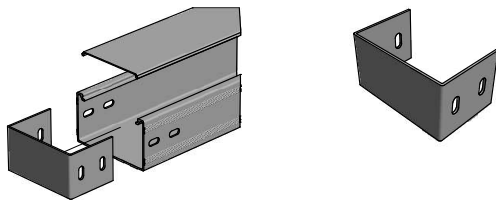

- 材 質: 鋁板 1050
- 厚 度: 2.0mm±0.2mm
- 表面處理: 陽極處理
- MATERIAL: ALUMINUM SHEET 1050
- THICKNESS: 2.0mm±0.2mm
- FINISH: ALUMINUM ANODIC TREATMENT

3 配電盤連接片 (PANEL PLATE CONNECTOR)

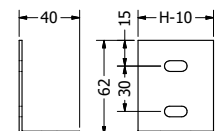
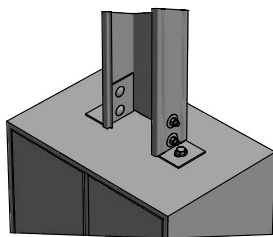

- 材 質: 鋁板 1050
- 厚 度: 2.0mm±0.2mm
- 表面處理: 陽極處理
- MATERIAL: ALUMINUM SHEET 1050
- THICKNESS: 2.0mm±0.2mm
- FINISH: ALUMINUM ANODIC TREATMENT

4 門型吊環 (HANGER CLAMP)

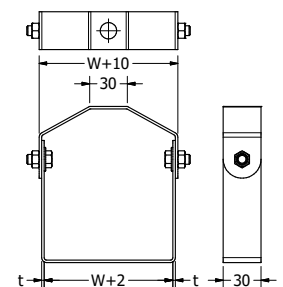
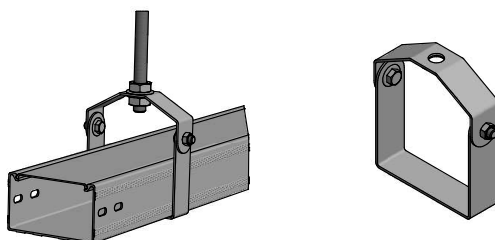

- 材 質: 不銹鋼板 SUS304
- 厚 度: 2.0mm±0.2mm
- 表面處理: 無
- MATERIAL: STAINLESS STEEL SUS304
- THICKNESS: 2.0mm±0.2mm
- FINISH: NONE

- 燈具吊夾 (LIGHTING CLAMP)
- 彎頭蓋板固定夾 (ELBOW COVER CLAMP)
- 馬車螺絲 (SQUARE NECK BOLT)

1 燈具吊夾 (LIGHTING CLAMP)

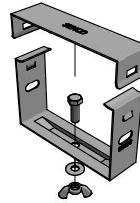
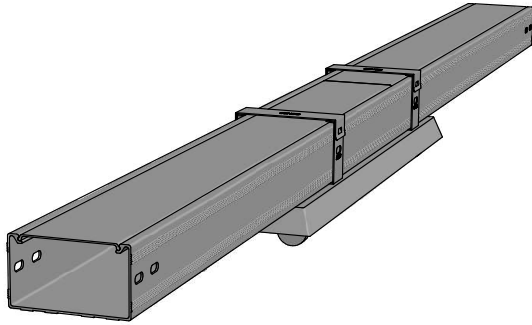

- 材 質: 不銹鋼板 SUS304
- 厚 度: 0.8mm
- 表面處理: 無
- MATERIAL: STAINLESS STEEL SUS304
- THICKNESS: 0.8mm
- FINISH: NONE

2 彎頭蓋板固定夾 (ELBOW COVER CLAMP)

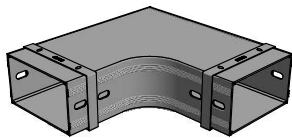

- 材 質: 不銹鋼板 SUS301
- 厚 度: 0.4mm
- 表面處理: 無
- MATERIAL: STAINLESS STEEL SUS301
- THICKNESS: 0.4mm
- FINISH: NONE

3 馬車螺絲 (SQUARE NECK BLOT)

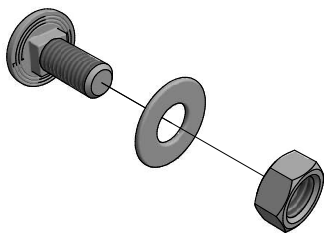

- 材 質: 不銹鋼 SUS304
- 尺 寸: 1/4" x 5/8" L
- MATERIAL: STAINLESS SUS304
- DIMENSION: 1/4" x 5/8" L